

# CARTAR Glidemaster Mobile

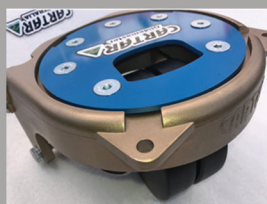

**Lift & Move -**



[www.cartar.com.au](http://www.cartar.com.au)  
australian made - australian quality

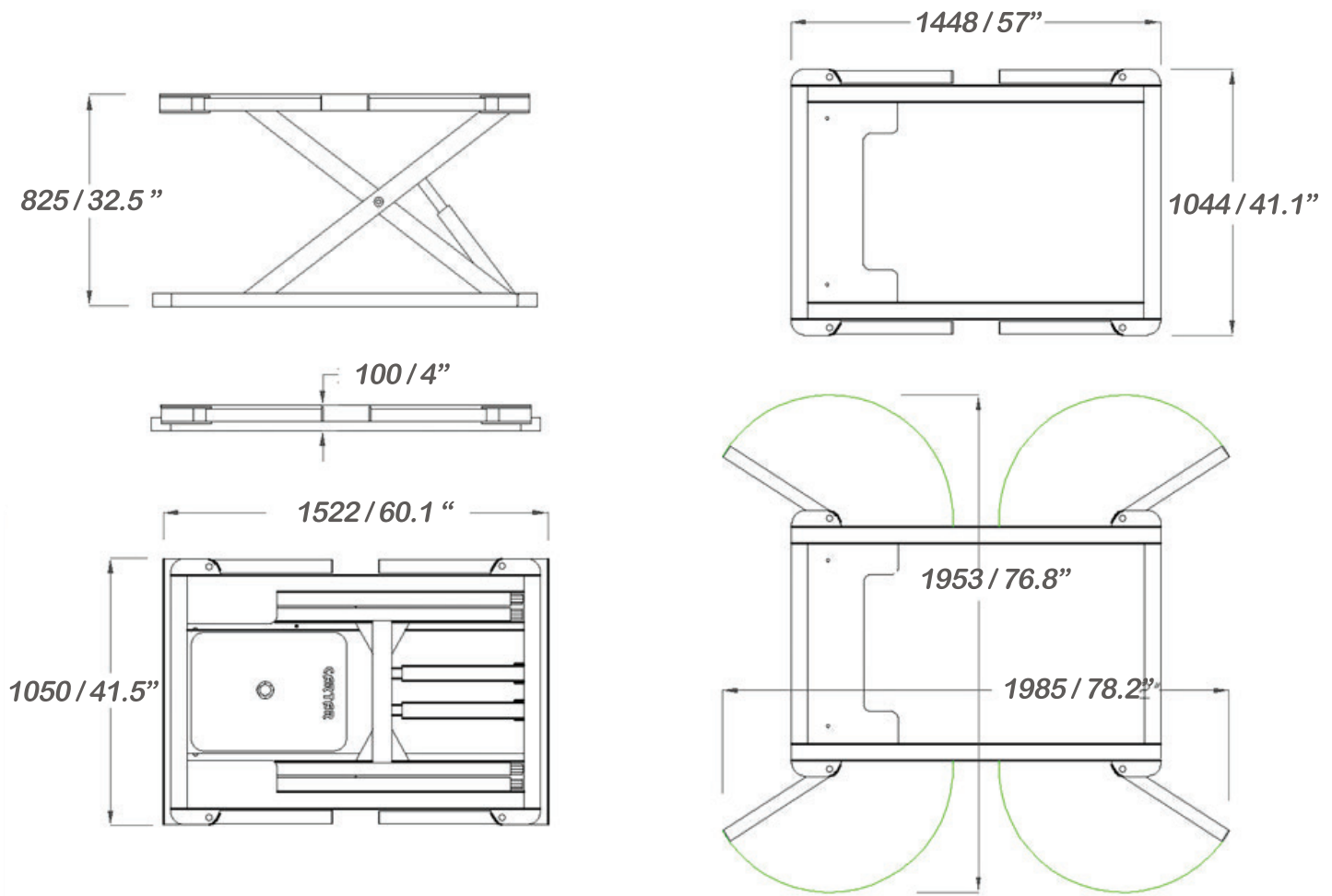

## Technical Specifications

**Overall Unit Length :**

**Glidemaster Mobile - 2000 mm**

**Econo 100 - 1522 mm**

<b>"Drive On " Ground Height</b>	<b>100 mm / 4 "</b>
<b>Elevated Height</b>	<b>820 mm/ 32.5"</b>
<b>Maximum Weight</b>	<b>2800 kg / 6210 lbs</b>
<b>Power Source</b>	<b>Compressed Air</b>
<b>Shipping Weight</b>	<b>265 kg / 584 lbs</b>
<b>Required Air Pressure</b>	<b>90 psi / 6.2 Bar</b>
<b>Average Air Consumption</b>	<b>13 cfm / 6.2 lpm</b>
<b>Air Consumption under Load</b>	<b>26.7 cfm / 12.6 lpm</b>
<b>Country of Manufacture</b>	<b>Australia</b>
<b>Power Pac</b>	<b>On Board</b>
<b>Factory Warranty</b>	<b>2 years Conditional</b>
<b>Weather Resistant</b>	<b>Inside or Outside</b>
<b>On Board Electrics</b>	<b>NIL</b>

# **CARTAR Econo 100**

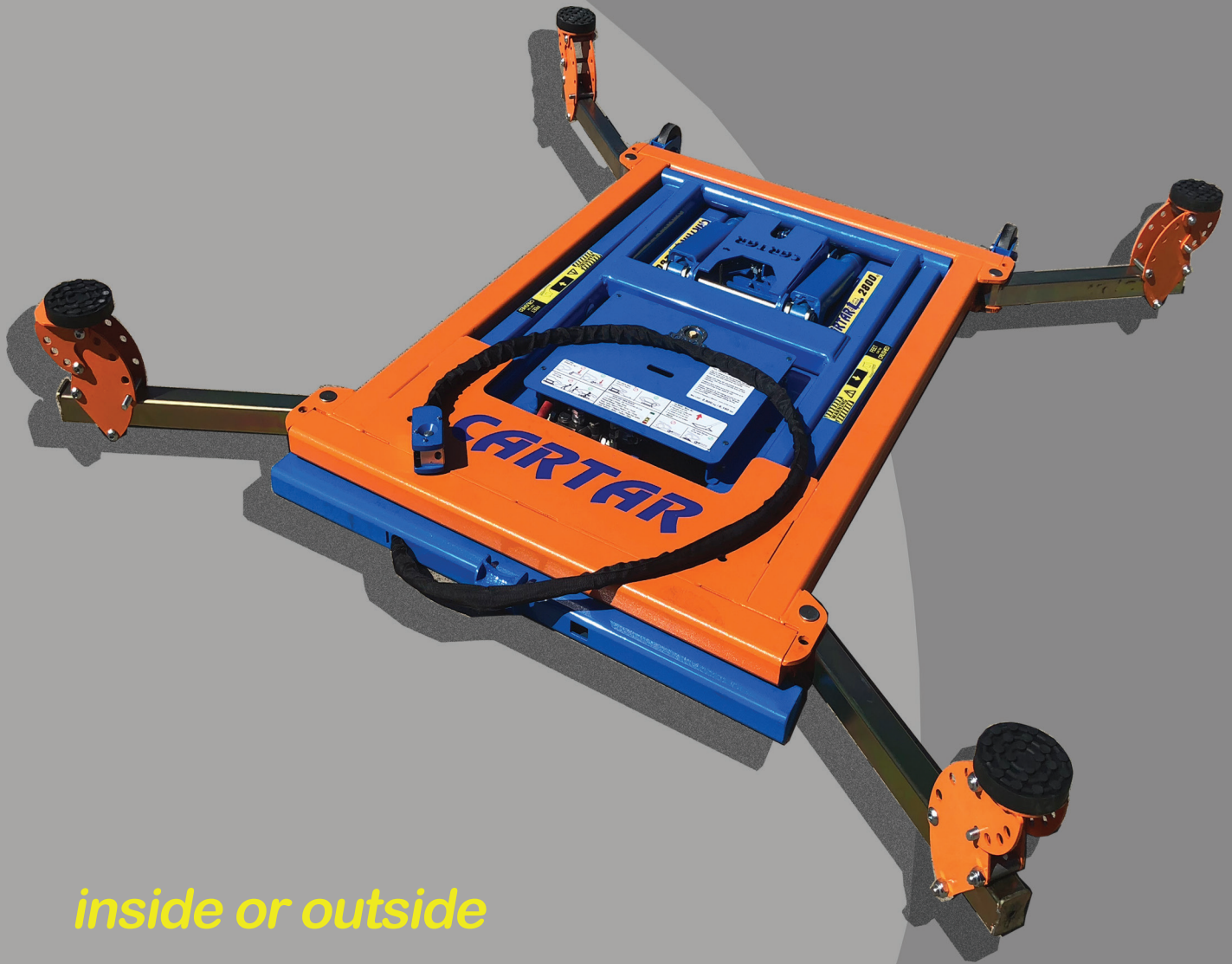

*inside or outside*

*100 mm drive over*

*air/ hyd - no installation costs*

[www.cartar.com.au](http://www.cartar.com.au)

**the new generation in “work-bay” Lifts  
australian made - australian quality**

# Cartar Lifts -

“innovation & quality all together”



## Head Office :

Cartar Australia  
P.O Box 90  
Mt.Martha  
Victoria , 3934  
AUSTRALIA  
tel: +61 418 504 311  
email : [info@cartar.com.au](mailto:info@cartar.com.au)  
skype : cartar1  
[www.cartar.com.au](http://www.cartar.com.au)

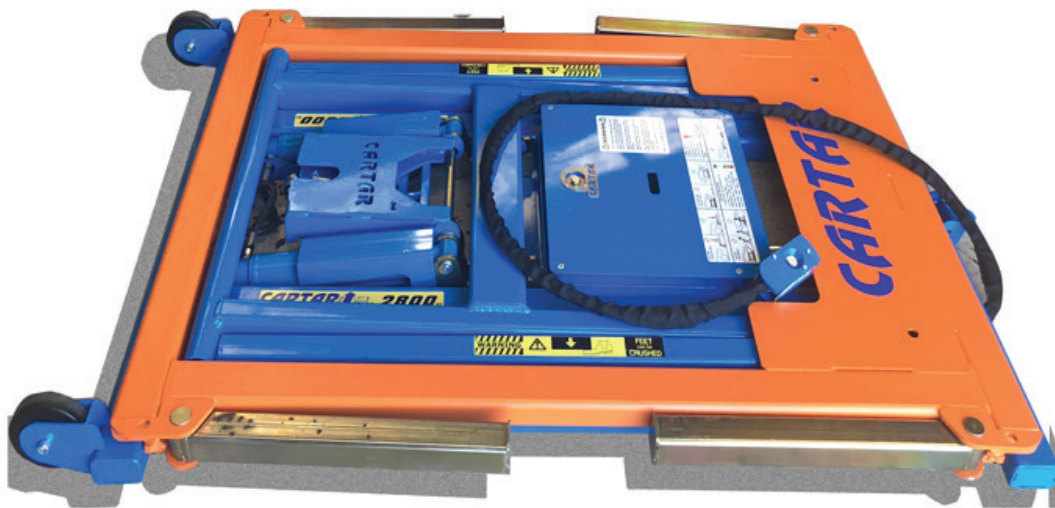

Australian Standards  
AS NZS 2550.9 -1996-  
Cranes-Safe Use . Part 9 - Vehicle Hoists



**CARTAR**   
mobile hoist technology